

Specification

Variants:	Reach	Payload	Armload
IRB 4600-60/2.05	2.05 m	60 kg	20 kg
IRB 4600-45/2.05	2.05 m	45 kg	20 kg
IRB 4600-40/2.55	2.55 m	40 kg	20 kg
IRB 4600-20/2.50	2.51 m	20 kg	11 kg

Main applications

Machine tending, Material handling, Arc welding, Cutting, Dispensing, Assembly, Palletizing and packing, Measuring, Deburring, Polishing

Features

Number of axes:	6+3 external (up to 36 with MultiMove)
Protection:	Standard IP67, Foundry Plus
Mounting:	Floor, semi-shelf inverted or tilted
Position repeatability (RP):	0.03-0.19 mm
Path repeatability (RT):	0.11-0.56 mm

Movement

Axis movements:	Working range:	Maximum speed:
Axis 1 Rotation	+180° to -180°	175°/s
Axis 2 Arm	+150° to -90°	175°/s
Axis 3 Wrist	+75° to -180°	175°/s
Axis 4 Rotation	+400° to -400°	250° (20/2.50 has 360°)/s
Axis 5 Bend*	+120° to -125°	250° (20/2.50 has 360°)/s
Axis 6 Turn	+400° to -400°	360° (20/2.50 has 500°)/s

* Axis 5 for IRB 4600-20/2.50 +120°-120°

Electrical connections

Supply voltage:	200-600 V, 50-60 Hz
-----------------	---------------------

Physical

Dimensions robot base:	512 x 676 mm
Robot height: IRB 4600-60/2.05 and IRB 4600-45/2.05	1727 mm
Robot height: IRB 4600-40/2.55 and IRB 4600-20/2.50	1922 mm
Robot weight:	412 to 435 kg

Environment

Ambient temperature for mechanical unit:

During operation:	+5° C (41° F) to +52° C (126° F)
Relative transportation and storage:	-25° C (-13° F) to +55° C (131° F)
For short periods (max 24 h):	up to +70° C (158° F)
Relative humidity:	Max 95%
Safety:	Double circuits with supervisions, emergency stops and safety functions. 3-position enable device
Emission:	EMC/EMI shielded

Working range

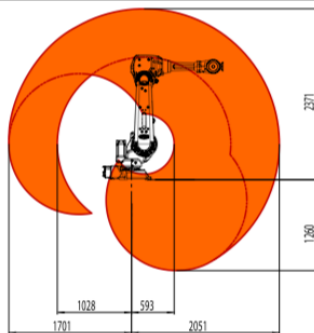

IRB 4600-60/2.05
IRB 4600-45/2.05

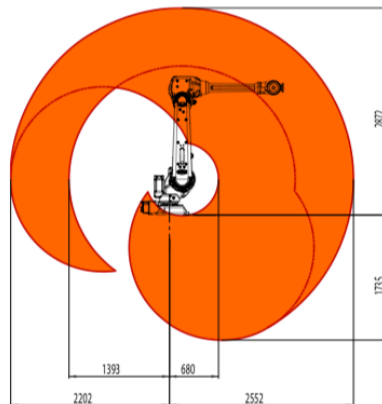

IRB 4600-40/2.55

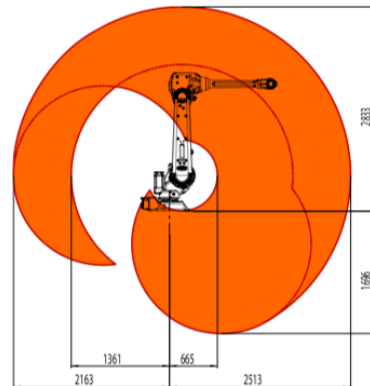

IRB 4600-20/2.50